

Alarms

IO 102-4

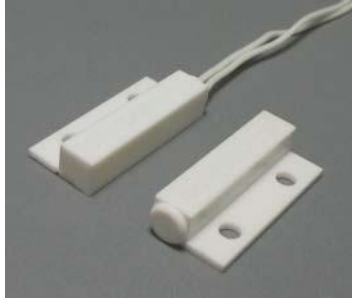

IO 102-4 security magnetically contact detector is designed for locking doorways and windows, arranging "trapping" medium as well as locking other elements of buildings with an alarm signal raised to a control panel, concentrator or central surveillance system by opening reed switch contacts.

Detector consists of a reed sensor and driving element (magnet) in plastic housing. It is designed for continuous operation.

Specifications

Switching voltage range	V	0,05 ... 72
Switching current range	mA	0,1 ... 250
Switching power, max	W	10
Life, min	-	$1 \cdot 10^6$
Output electrical resistance:		
• at closed contacts (at (100 ± 10) mA), Ohms, max	-	0,5
• at open contacts, kOhms, min		200
If sensor and magnet are located parallel contacts should be:		
• closed – at the distance between them	mm	10 and less
• open – at the distance between them		45 and more
Allowable offset of sensor and magnet, max	mm	3
Insulation resistance between leads of sensor, min:		
• in normal climatic conditions	Ohms	$5 \cdot 10^6$
• at high relative humidity 98% at $+35^\circ\text{C}$		$2 \cdot 10^5$
Breakdown voltage between sensor leads and case, min	V_{AC} / V_{DC}	500 / 700
Operating temperature range	$^\circ\text{C}$	-50 ... +50
High humidity at $+35^\circ\text{C}$, max	%	98
Vibration proof at 10 to 35 Hz, max	m/sec^2	4,9
	(g)	(0,5)
Failure free operation time, min	h	200000
Life time, min	years	8
Weight, max	g	8,8

Installation:

$\varnothing 3 \times (12 \dots 15)$ mm screws are applied to the wooden surface. Installation onto the metal surface is performed with the help of wooden, cloth laminate layer, etc. with thickness of 25-30 mm. It is glued onto the glass surface. Sensor leads are connected to the line by twisting and soldering with insulation followed.

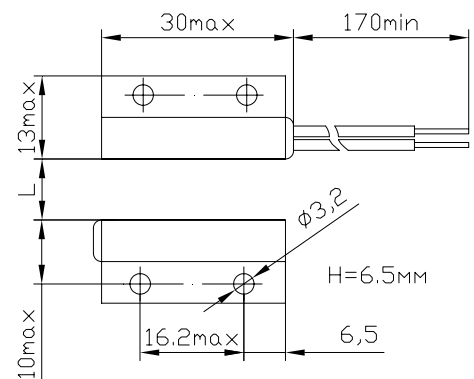

Information could be subject to changes. For details please contact marketing department.

15.09.2011



www.rmcp.ru

JSC "RYAZAN METAL CERAMICS INSTRUMENTATION PLANT"

Russia, 390027, Ryazan, Novaya street, 51 «B»

Marketing: Tel./Fax: (4912) 24-02-34, e-mail: marketing@rmcp.ru

Sales: Fax: (4912) 24-02-34, 44-19-70, 44-68-07

