

Limit reed switch

SKV-03



SKV - 03 limit reed switch is intended for application as driving element in aircraft control units. The switch consists of reed sensor and driving element (magnet).

Specifications

Operate distance	mm	3 ... 15
Differential pitch	mm	1,5 ... 9
Switching power, max - at resistive load, W - at inductive load, VA - at lamp load, VA	W/VA	30 30 5
Switching current range	A	0,001 ... 1,0
Switching voltage, max	V	30
Resistance of closed contacts (without leads), max	Ohms	0,3
Insulation resistance of open contacts, min	MOhms	20
Breakdown voltage, min	$V_{AC}/$ V_{DC}	127/ 180
Switching frequency, max	oper / sec	5
Sinusoidal vibration (1-2000)Hz, max	g	10
Acoustic noise (50-10000)Hz, max	dB	150
Mechanical shock, max - single shock, duration (0,1-2)msec - multiple shock, duration (1-5)msec	g	750 150
Linear acceleration, max	g	100
Operating temperature range	$^{\circ}C$	-60 ... +85
High humidity at +25 $^{\circ}C$, max	%	98
Weight, max	g	60

Life time and safety

- 1) In mode 1,0A-30V inductive load, DC $\tau \leq 0,008s$ (valve with spark protection) on N.O. and 0,16A – 30V lamp load on N.C. – not less than $2 \cdot 10^5$ operations at switching frequency not more than 5Hz;
- 2) In mode 0,16A-30V lamp load, DC on N.O and N.C. – not less than $2 \cdot 10^5$ operations at switching frequency not more than 5Hz;
- 3) In mode 1,0A-30V resistive load, DC on N.O and N.C. - not less than $2 \cdot 10^5$ operations at switching frequency not more than 5Hz.

Marking of switch contacts

- contact N.O. – “yellow”
- common contact – “red”
- contact N.C. – “white” or “green”

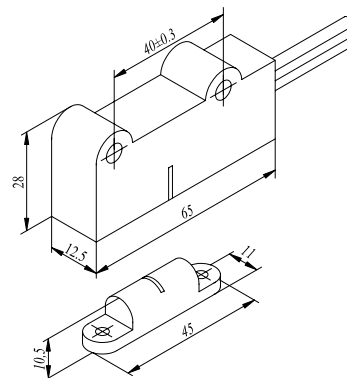

Information could be subject to changes. For details please contact marketing department.

16.09.2011



www.rmcp.ru

JSC "RYAZAN METAL CERAMICS INSTRUMENTATION PLANT"

Russia, 390027, Ryazan, Novaya street, 51 «B»

Marketing: Tel./Fax: (4912) 24-02-34, e-mail: marketing@rmcp.ru

Sales: Fax: (4912) 24-02-34, 44-19-70, 44-68-07

